

## 390ml / 12oz (90mm) Black Aqueous Double Wall BioCup BC-12DWB

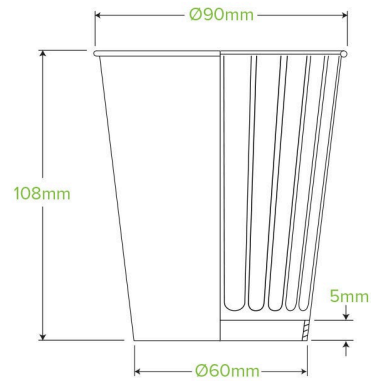

12oz Aqueous Double Wall BioCups are manufactured using a unique water-based dispersion coating certified home compostable to Australian standards (AS5810). These cups are food safe, odorless, and can be disposed of right in your backyard compost bin!

<b>Carton quantity:</b> 1000	<b>Sleeves per carton:</b> 25	<b>Units per sleeve:</b> 40
<b>Carton Size LxWxH (cm):</b> 46.5x46.5x59.5	<b>Carton gross weight (kg):</b> 18.600000	<b>Raw Material:</b> Paper - FSC™ Mix certified paper
<b>Lining/coating:</b> Aqueous	<b>Window Material:</b> None	<b>Inks:</b> Food Contact Safe Inks
<b>Brim fill capacity (ml):</b> 391	<b>Dimensions top LxW (mm):</b> 90x90	<b>Dimensions base LxW (mm):</b> 60x60
<b>Product Depth:</b> 108	<b>Product weight (g):</b> 18	<b>Thickness:</b> 300gsm+260gsm+8g aqueous
<b>Use:</b> Hot and cold	<b>Manufactured:</b> China	<b>Customise:</b> Print
<b>MOQ custom:</b> 50000	<b>Mould fees:</b> Yes - see custom packaging	<b>Quality product certified:</b> TBC
<b>Factory food safety certified:</b> BRC	<b>Corporate social accreditation:</b> BSCI	<b>Home compostable:</b> Certified to AS5810 Australian standards, Certified to NF T51-800 European standards
<b>Industrially compostable:</b> Certified to AS4736 Australian Standards, Certified to EN13432 European Standard	<b>Recyclable:</b> No	